

# Manual ShowLED Classic Controller



email [enquiries@ssld.co.uk](mailto:enquiries@ssld.co.uk)

tel: 024 76348 890 mobile: 07792 015055

## Wiring the starcloth to the controller

Connecting one cloth to the controller

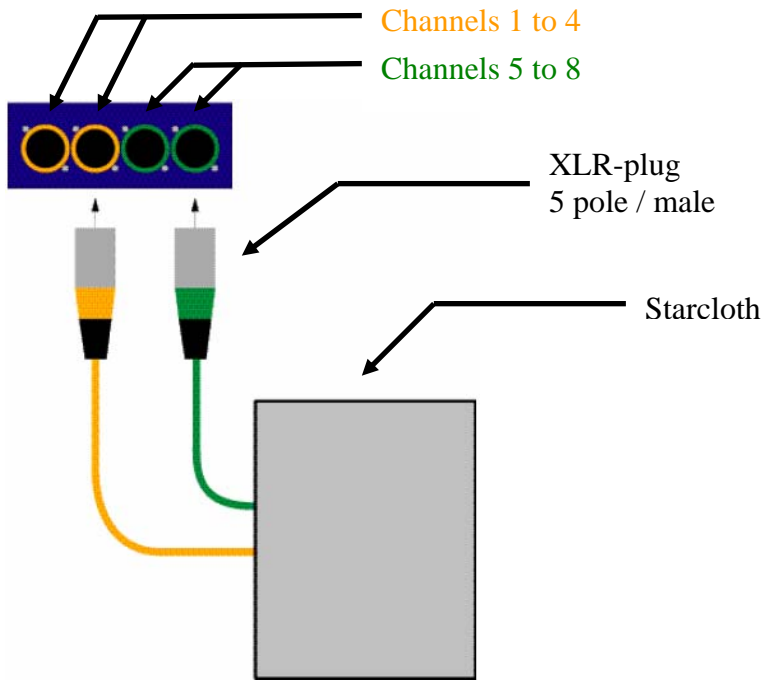

Connecting two small cloths to the controller

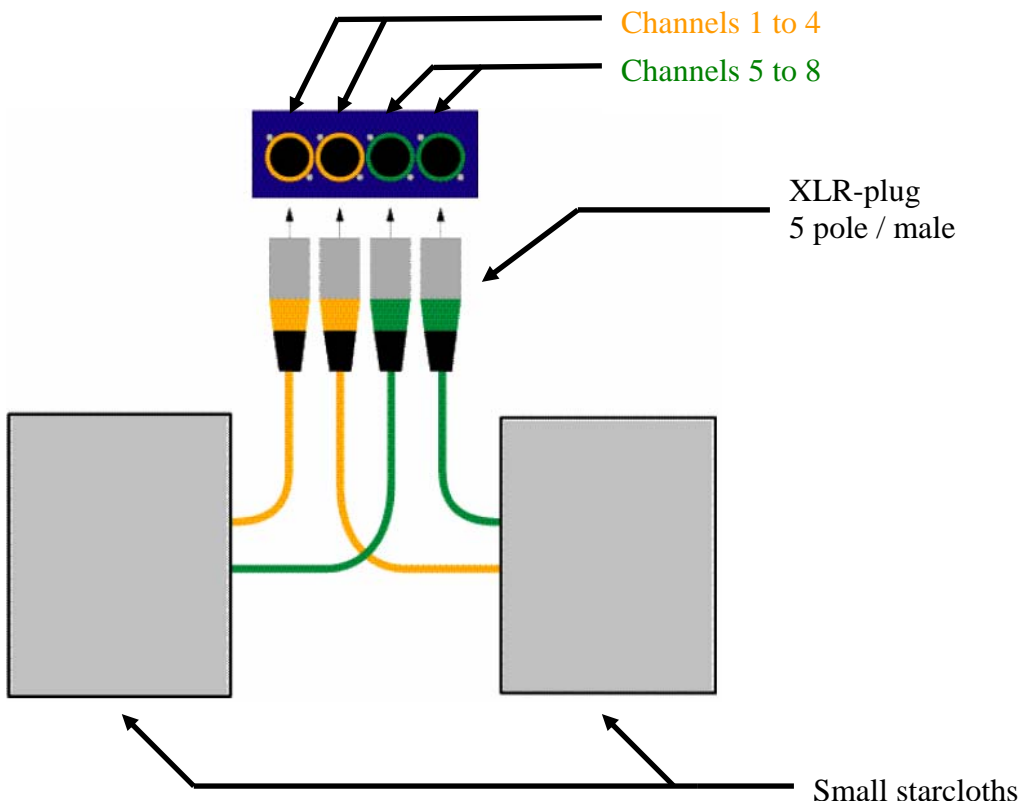

Note: The connectors with the same colour code are switched in parallel (internally)

## Connecting the ShowLED controller

1. Connect your application<sup>1</sup> to the LED output connectors of the controller.
2. Connect the powercord to the MAINS (90-260V) input of the controller.
3. At this point you will need to set the parameters of the controller. You will learn how to do so from this manual.
4. If you have more than one controller to connect. See setting up the control network, further in this manual.

## Setting up the control network

The control network is set up with the use of 5 pole XLR cables. In the following drawings only the control network is drawn. Depending on your application, you will choose a configuration.

### Stand Alone Mode

#### Configuration 1: Master slave operation (No lightboard present)

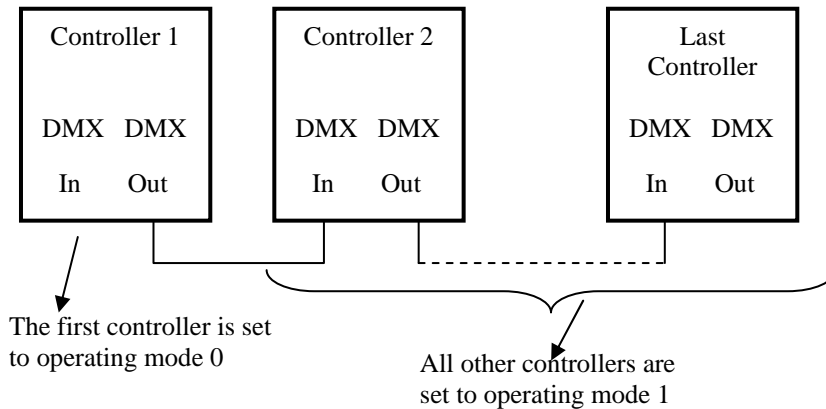

### DMX Mode

#### Configuration 2: Using the build in patterns (With use of a lightboard)

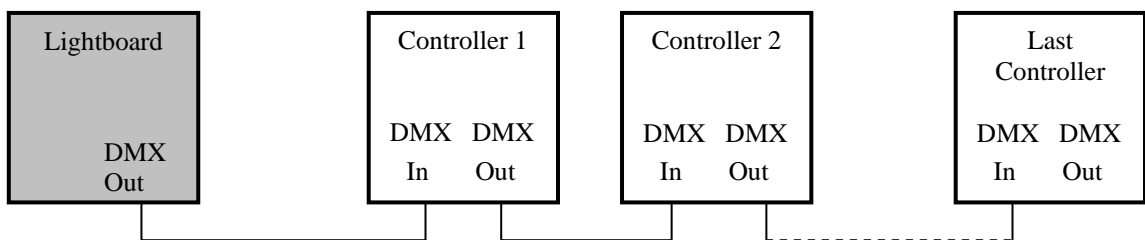

In this configuration controller 1 is set in mode 10; all the others are set in mode 1.

This configuration requires minimum 5 DMX channels.

Note that if you want to add another device to this control network, it can be put only before the first controller!

<sup>1</sup> For instance, a starcloth, a logo, ...

### Configuration 3: Dimming function of each output

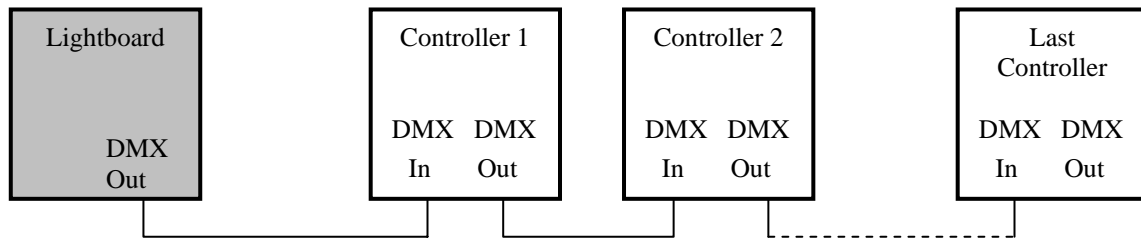

In this configuration all the controllers are set in mode 8.

This configuration requires minimum 8 DMX channels.

You can choose if you want to address the controllers all together or separately.

By setting all the controllers in this control network on the same DMX base you can address all the controllers together.

By setting all the controllers in the control network on a different DMX base (e.g. 1, 9, 17, 25 ...) you can address all the controllers separately. Note that if you want to address all the controllers separately, you will need 8 DMX channels per controller. (e.g. 4 controllers require 32 channels)

### Mixing controllers with different firmware

#### Stand Alone Mode

#### Configuration 4: Master slave operation (No lightboard present)

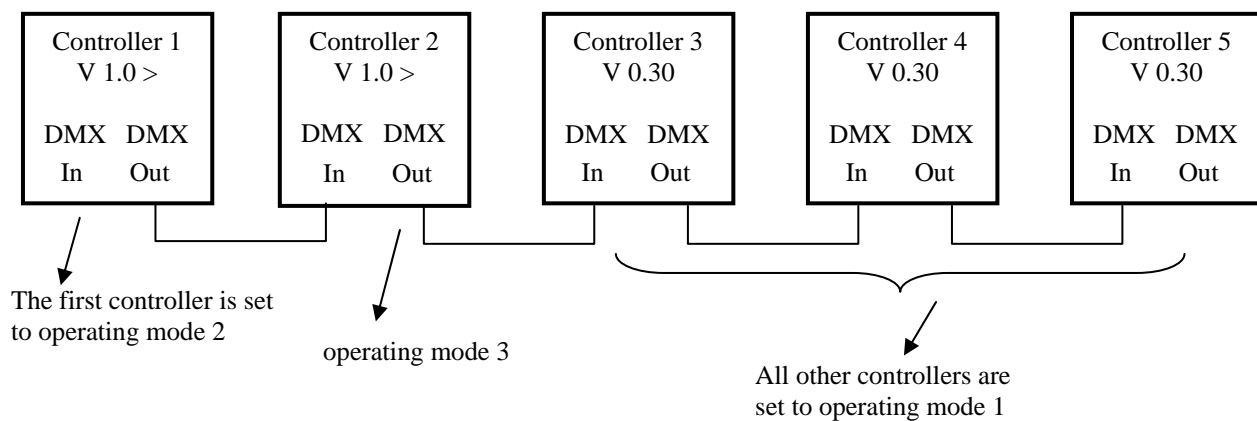

#### Legend:

V 1.0 >: firmware version 1.0 or higher

V 0.30: firmware version 0.30

## DMX Mode

### Configuration 5: Using the build in patterns (See also configuration 2)

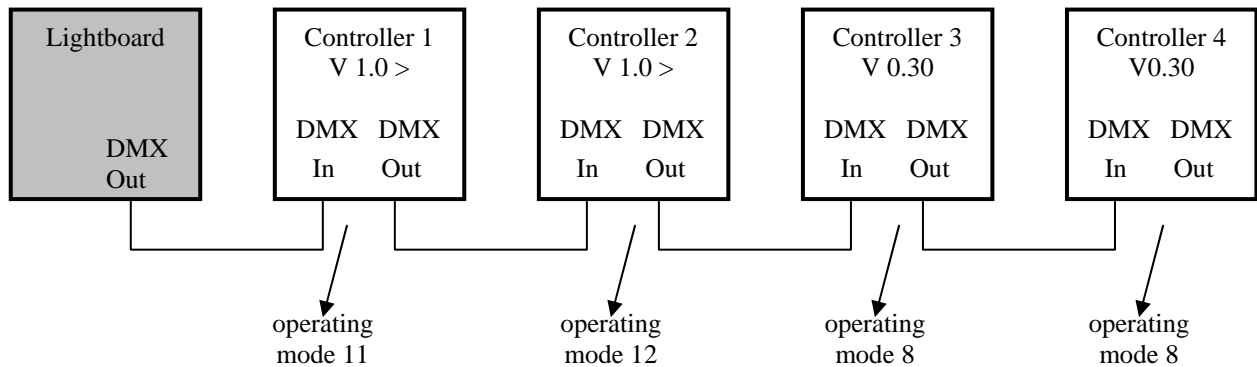

### Configuration 6: Dimming function of each output (See also configuration 3)

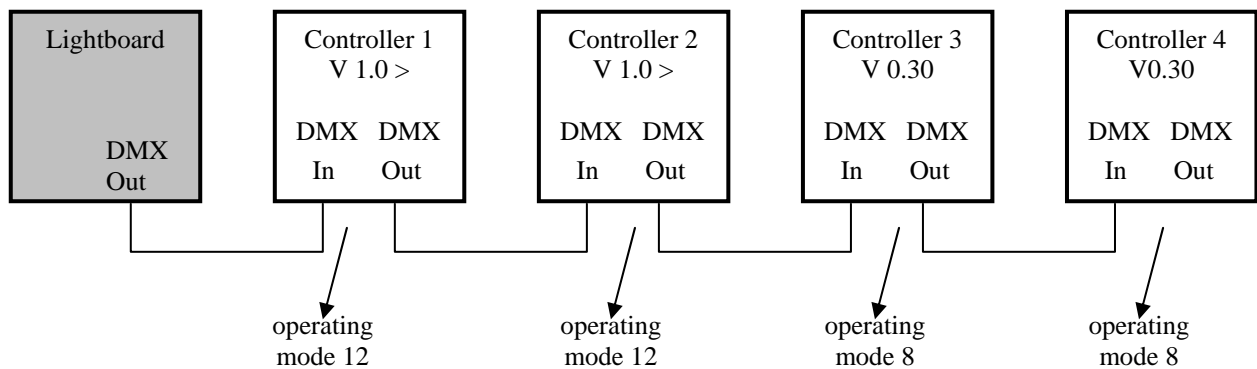

#### Legend:

- V 1.0 >: firmware version 1.0 or higher
- V 0.30: firmware version 0.30



## Description of the parameters

### Operating mode

This is the first parameter you need to set before entering the other ones.  
Depending on the configuration of your application you must choose a certain operating mode.  
See also section “Setting up the control network” for more clarity.

Mode	DMX channel requirements	Description	Access to the operational parameters	Dimmer curve
0	*	Stand-alone operation (Master)	On the controller (menus)	Improved
1	*	Stand-alone operation (Slave, listens to other controller in mode 0)	*	Improved
2	*	Stand-alone operation (Master)	On the controller (menus)	Standard
3	*	Stand-alone operation (Slave, listens to other controller in mode 0)	*	Standard
4	*	reserved	*	*
5	*	reserved	*	*
6	*	reserved	*	*
7	*	reserved	*	*
8	8	Dimming function of each output	*	Improved
9	5	Pattern type, Pattern behaviour, Chase speed, Min. Intensity, Max. Intensity	By the DMX signal	Improved
10	5	Pattern type, Pattern behaviour, Chase speed, Min. Intensity, Max. Intensity (solves synchronisation problems)	By the DMX signal	Improved
11	5	Pattern type, Pattern behaviour, Chase speed, Min. Intensity, Max. Intensity (solves synchronisation problems)	By the DMX signal	Standard
12	8	Dimming function of each output	*	Standard
13	*	reserved	*	*
14	*	reserved	*	*
15	*	reserved	*	*

\*: Doesn't apply

#### Notes:

- Mode 0: The controller will act as a lightboard for the other controllers.
- Mode 9: You can address remotely the operational parameters by the DMX-signal.  
It will save you time; you don't have to program your own sequences.

### DMX base

Use this parameter to set the DMX base address of the ShowLED controller.  
The DMX base address can be set between 1 and 504.

The following build in patterns are only available if operating mode 0, 2, 9, 10 or 11 are selected!!!  
 If operating mode 0 or 2 are selected, they are available on the operator console. If operating mode 9, 10 or 11 are selected, they are available through the DMX signal.

## Pattern Type

(Channel offset 0)

DMX value	Function	Description
0.. 7	All Channels OFF	*
8.. 31	Chase Pattern 1	Random, min. 3 channel on
32.. 55	Chase Pattern 2	Special
56.. 79	Chase Pattern 3	Sequence with 4 channels on
80.. 103	Chase Pattern 4	Sequence with 5 channels on
104.. 127	Chase Pattern 5	Sequence with 6 channels on
128.. 151	Chase Pattern 6	Running light 7 channels on
152.. 175	Chase Pattern 7	Running light 6 channels on
176.. 199	Chase Pattern 8	Running light 5 channels on
200.. 223	Chase Pattern 9	Running light 4 channels on
224.. 247	Chase Pattern 10	STROBE
248.. 255	All Channels ON	*

\* Forced operation, all other parameters have no influence.

## Pattern Behaviour

(Channel offset 1)

DMX value	Description
0.. 63	Soft chase
64.. 127	Hard chase
128.. 191	Soft chase, inverted pattern
192.. 255	Hard chase, inverted pattern

## Chase Speed

(Channel offset 2)

DMX value	Description
0	Minimum speed
..	
255	Maximum speed

## Minimum Intensity

(Channel offset 3)

Limiter function sets the minimum intensity level. When set to a value higher than zero, the LEDs will not dim completely.

## Maximum Intensity

(Channel offset 4)

Limiter function sets the maximum intensity level. When set to a value lower than 255, the LEDs will not burn at full capacity.

Note that the maximum intensity has a higher priority than the minimum intensity!

## Graphical presentation of the DMX channel arrangement

This is only valid if operating mode 9, 10 or 11 is selected.  
 This can be of help when you are using a low-cost DMX lightboard.

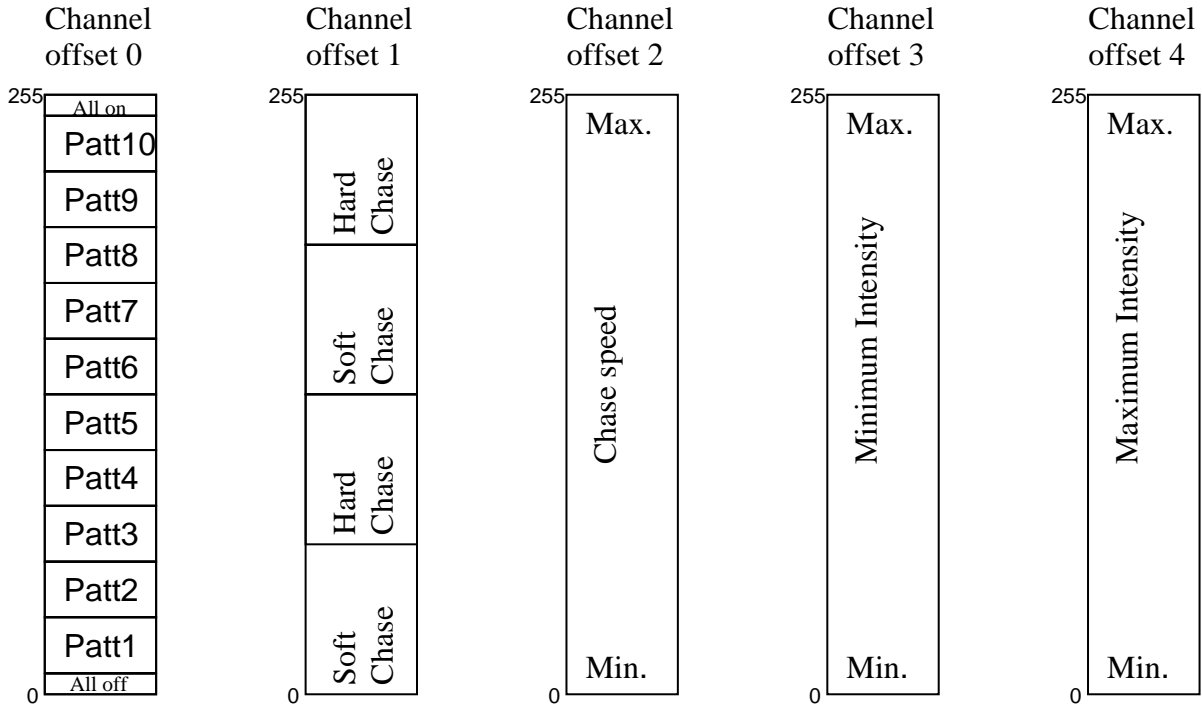

This is only valid if pattern 2 is selected.

